



Brakel® Ventria



Stylish ventlight

This transparent top-hung window provides natural ventilation for both smoke and hot air. Thanks to its attractive external design the Ventria is often integrated into glazed facades and glazed roofs for air feed and air extraction. The Ventria is available in both a thermally insulated and standard insulated/uninsulated design and is suitable for all types of glass up to a thickness of 40 mm. Applications: from industrial to decorative glazed roof constructions.

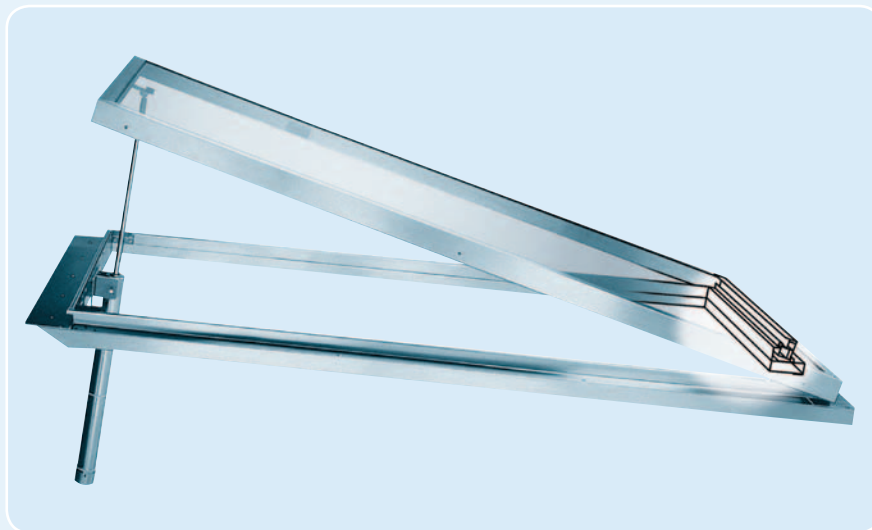

Controls

Compressed air cylinder, CO₂ control, electric spindle motors or rotary spindle with control block. Opening angle depends on the selected stroke length for the control mechanism. Brakel supplies the compressed air controls with a double-action compressed air cylinder that is locked in its open and closed state.

Designs

The Ventria is a hinged ventlight that can be incorporated into glazed roofs and glazed walls. The opening angle of the window in relation to the base structure is variable up to a maximum of 75°. The structure consists of tempered aluminium, sea water corrosion-resistant AlMg3.

Extruded material made of AlMg Si 0.5. The frame is sealed with EPDM rubbers to ensure optimal sealing. The Ventria can be supplied both uninsulated (Ventria-O), insulated (Ventria G) and heat-insulated (Ventria TG).

The Ventria can be supplied in both untreated and anodised designs or powder-coated (in any RAL colour you require). Amongst other things, the following infills can be integrated into this ventlight: single- or double-walled aluminium panel, laminated glass, insulated glass, double-walled and triple-walled polycarbonate.

External appearance, dimensions, weight etc.

Any rectangular shapes are possible as standard with a:

- maximum height of 2700 mm
- maximum width of 2000 mm
- maximum surface area of 3.5 m²
- maximum weight of the panel is 35 kg/m²

Alternative dimensions, panels and shapes can be supplied on demand.

The weight depends on dimensioning and panel.

The maximum weight of the panel is 35 kg/m².

Regulations

The system is tested and certified in accordance with EN 12101-2.

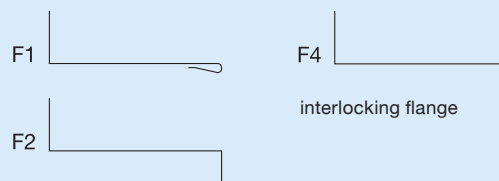

Flanges

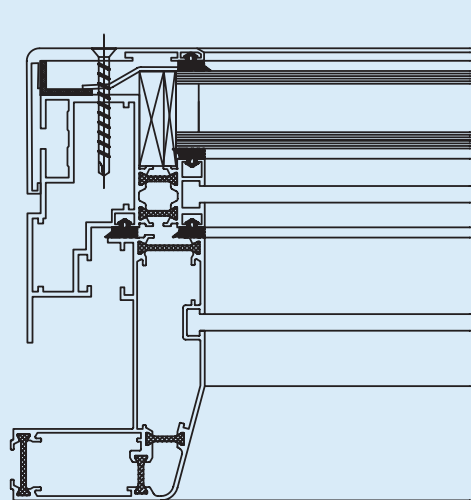

Cold bridge-free

Ventria-TG, cold bridge-free



Ventria-O, uninsulated open

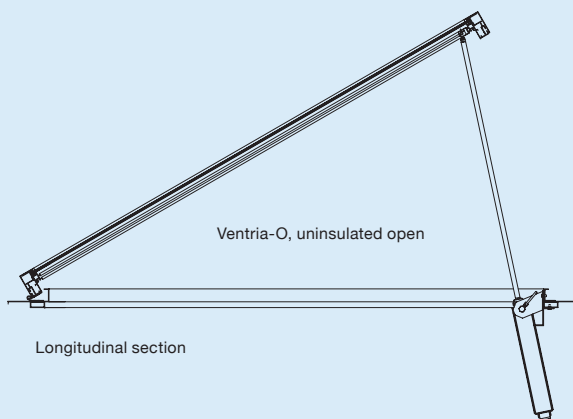

Cross sections

